



*George Daniels*

*DOC | \*audiobook | ebooks | Download PDF | ePub*

Copyrighted Material

GEORGE DANIELS

# WATCHMAKING

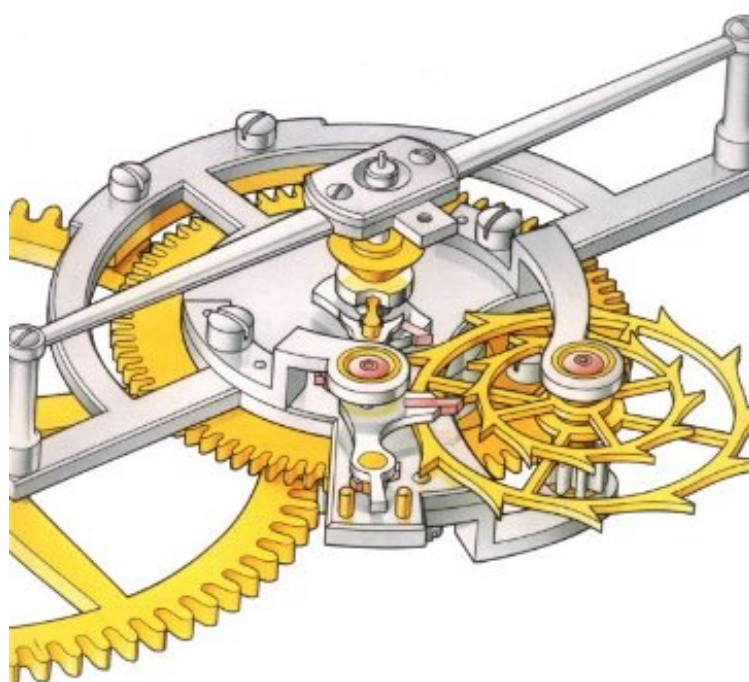

Copyrighted Material

[Read free] Watchmaking

## Watchmaking

**George Daniels : Watchmaking** before purchasing it in order to gage whether or not it would be worth my time, and all praised Watchmaking:

35 of 38 people found the following review helpful. A step by step account by the most creative Watchmaker aliveBy Fortunat Mueller-maerkiGeorge Daniels, residing on the Isle of Man, (UK) is not only one of a handfull of people alive today who regularly make one-of-a-kind watches completely from strach by themselves (including dial, case, movement, hands etc), but he unquestionably is the most creative of the few who are truely "watchmakers" (rather than watch repaireres or workers in a watch factory.The republishing of "Watchmaking", after it has been out of print for many years must be one of the outstanding events of this year in horological book publishing. Every serious watch collector around the world, who had been lusting for his own copy after seeing copies of older watchcollecting friends

can now afford to buy his or her own copy, rather than pay the outrageous prices at antiquarian booksellers. The book is undoubtedly the most important volume in currently in print (was promised for Jan 1999, finally first copies delivered in April 1999) for horologists and enthusiasts about craftsman made watches anywhere. A "must" for anybody interested in watchmaking techniques and watchmaking technology. Fortunat F. Mueller-Maerki Publisher of HOROLOGY - The Index 52 of 56 people found the following review helpful. The best technical treatise on fine watchmaking By Tom Bales (tob@starhouse.org) This book contains the complete details of making a George Daniels watch, including the methods of fabricating and finishing every single part in the watch. George Daniels is thought by many to be the premier watchmaker in the world today, and in this book he details the methods he uses to make each component of his watches. Also included is a detailed description of the operation of gear trains, complications, and escapements, including the Daniels co-axial escapement. If you have any aspirations to watchmaking or just want to see how the absolute best are made, this is the definitive book. Wonderful color plates and technical drawings.

This is the second reprint of the standard work on watchmaking; indispensable to watchmakers and restorers of mechanical watches. George Daniels completed his first watch in 1969, arousing enough interest to generate a renaissance in the art and skills of designing and making individual watches. Watchmaking describes every aspect of the antique craft of watch construction. Line drawings detail every manufacturing technique employed, and completed watches and their component details are illustrated in color. The author's principal aim in writing this book has been to inspire and encourage the art of watchmaking, especially among a new generation of enthusiasts. As a supreme master of this art, his advice is constantly sought both by students and watch repairers. His understanding of the problems that can beset the would-be watchmaker, especially in an age of mass production, his expert knowledge of the history of watchmaking, together with his concern for the continuation of the art, have convinced him of the need for a comprehensive study of the subject. One of the most interesting aspects of George Daniel's work, which this book describes, is that he makes every component of the watch himself. In addition to explaining the techniques required, many of which he has evolved himself, Daniels describes the tools that will be necessary for working, both by hand and machine, and also defines the ideal workshop and its contents. The making of the precision timekeeper is described, step by step, and is illustrated at each stage with line drawings and brief explanatory captions. The text is easy to follow and care has been taken to avoid complicated technical descriptions.

About the Author George Daniels, MBE, DSC (HONS), FSA, FCGI, FBHI, FAWI, is a practising horologist with fifty years' experience in both antiquarian and modern watchmaking and is a pastmaster of the Worshipful Company of Clockmakers. Amongst his awards for contribution to the art and science of watchmaking - including the design of his own escapements - are The Tompian Gold Medal, The British Horological Institute Gold Medal, The City and Guilds of London Gold Medal, The Arts Sciences and Learning award of the City of London and the Victor Kullberg Medal of the Stockholm Watchmakers' Guild.